



Yes, you can.[®]

Invacare[®] Etude Medley



User Manual (GB)

Bedienungsanleitung (DE)

Gebruiksaanwijzing (NL)

Manuel d'utilisation (FR)

Brugervejledning (NO)

Manual del usuario (ES)

Manuale d'uso (IT)

Manual de Utilização (PT)

Illustration 1

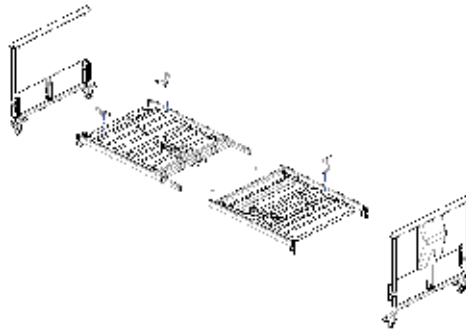

Illustration 2 a

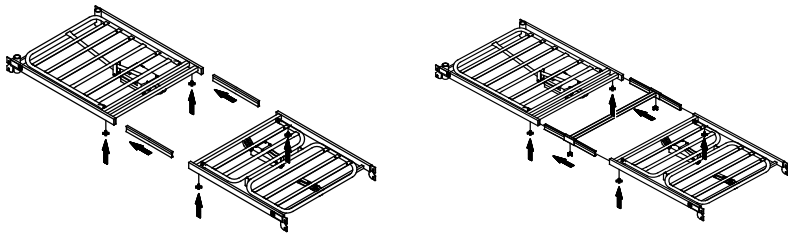

Illustration 2 b

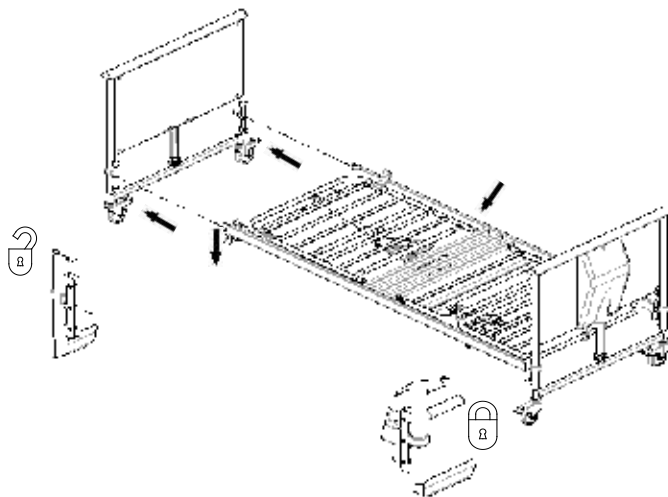

Illustration 2 c

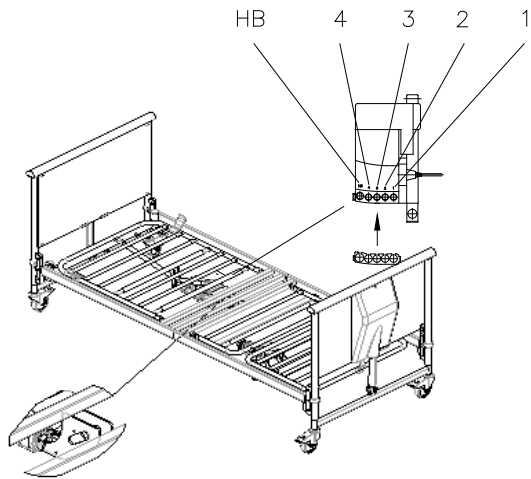

Illustration 3

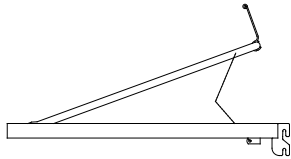

Illustration 4

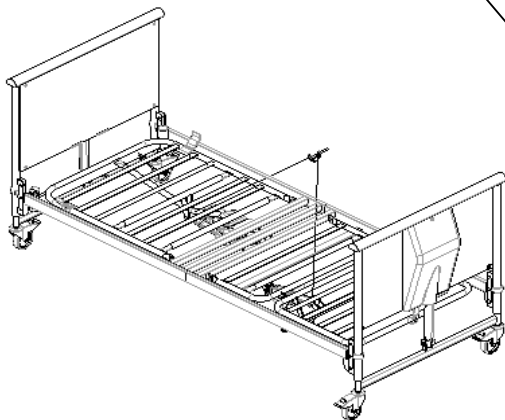

Illustration 5

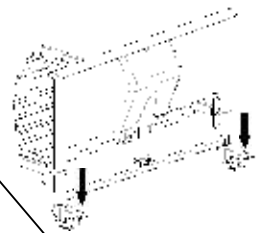

Illustration 6

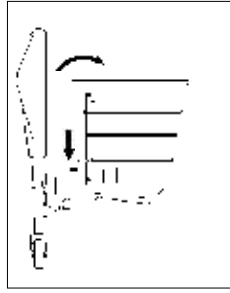
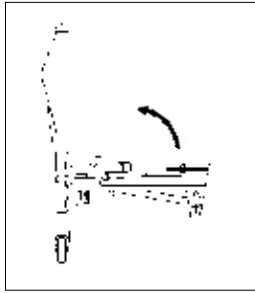
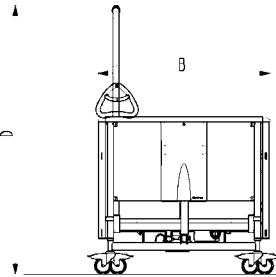
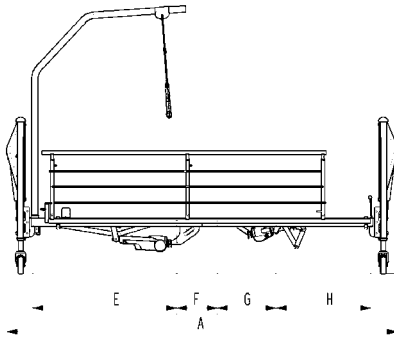

Illustration 7



Etude Medley



4-sectioned

Medley (mm)		
	Lower hinge	Upper hinge
A	2215	
B	1020	
C	330-730	400-800
D	1565-1965	1635-2035
E	750	
F	350	
G	340	
H	560	

Medley low version (mm)		
	Lower hinge	Upper hinge
A	2215	
B	1020	
C	220-620	290-690
D	1455-1855	1525-1925
E	750	
F	350	
G	340	
H	560	

Quality Declaration

Congratulations with your new bed Invacare® Etude Medley from Invacare®.

Your new bed is  -marked in accordance with directive 93/42/EEC concerning medical devices.

Invacare® Etude Medley is developed and constructed with consideration for the user and others handling or assisting at the bed. Furthermore, the bed is developed in accordance with the European Standard EN 1970/A1 & EN 60601.2.38.

Invacare® Etude Medley is supervised and quality controlled throughout the entire production process, and the finished bed is inspected by our finished goods control. Identification label and QA-mark are located on the bed confirming that the finished goods control has approved the bed.

Please read the entire user's manual before using the bed.

Invacare® is certified according to ISO 9001 and ISO 13485.

DK

KVALITETSDEKLARATION

Tillykke med Deres nye seng *Invacare® Medley* fra *Invacare®*.

Deres nye seng er CE - mærket og lever op til alle krav i henhold til direktiv 93/42/EOF om medicinske anordninger.

Sengen er udviklet og konstrueret under stort mulig hensyntagen til brugeren samt alle andre, der enten håndterer sengen eller hjælper til ved sengen.

Invacare® Medley er udviklet under hensyntagen til de sikkerhedsmæssige krav i den Europæiske Standard EN 1970 /A1 & EN 60601.2.38. Hver seng har gennem hele produktionsforløbet været overvåget og kontrolleret, og den færdige seng er blevet inspiceret af vores færdigvarekontrol.

Typeskilt og QA-mærke påsættes sengen som dokumentation for, at færdigvare kontrollen har godkendt sengen. For ibrugtagning af Deres seng skal De gennemlæse brugermanualen grundigt. *Invacare®* er certificeret i henhold til ISO 9001 og ISO 13485.

DE

QUALITÄTSDOKUMENTATION

Herzlichen Glückwunsch zu Ihrem neuen Pflegebett *Invacare® Medley* von *Invacare®*.

Ihr neues Pflegebett ist gemäß der Richtlinie 93/42/EWG für Medizinprodukte CE-gemessen.

Das *Invacare® Medley* wurde unter Berücksichtigung der Bedürfnisse von Benutzer und Pflegepersonal entwickelt und in Übereinstimmung mit der Europäischen Norm

EN 1970 /A1 & EN 60601.2.38. konzipiert und hergestellt.

Während des gesamten Herstellungsprozesses unterliegt das *Invacare® Medley* einer ständigen Qualitätskontrolle und wird im Anschluss nochmals durch unsere

Endkontrolle geprüft. Das Typenschild und QA-Kennzeichen sind am Bett angebracht, um die Abnahme durch unsere Qualitätskontrolle zu bestätigen.

Bitte lesen die gesamte Bedienungsanleitung, bevor Sie das Bett in Gebrauch nehmen.

Invacare® ist zertifiziert nach ISO 9001 und ISO 13485.

NL

KWALITEITSGARANTIE

Gefeliciteerd met de aanschaf van uw nieuwe bed *Medley* van *Invacare®*.

Invacare® Medley is CE - gecertificeerd en goedgekeurd conform richtlijn 93/42/EEC betreffende medische hulpmiddelen.

Invacare® Medley is ontwikkeld en geconstrueerd met inachtname van de behoeften van de gebruiker en verzorgers.

Invacare® Medley is ontwikkeld in overeenstemming met de Europese Standaard EN 1970 /A1 & EN 60601.2.38.

Gedurende het gehele productieproces is het *Medley* bed gecontroleerd op kwaliteitsaspecten en het complete bed is na productie zorgvuldig gecontroleerd. Het productlabel en de

QA-markering zijn op het bed bevestigd om aan te tonen dat de bedden zijn gecontroleerd en goed zijn bevonden door de afdeling productiecontrole. Wij verzoeken u vriendelijk de gehele gebruikerhandleiding te lezen voordat u het bed in gebruik neemt.

Invacare® is ISO 9001 en ISO 13485 gecertificeerd.

IT

DICHIARAZIONE DI QUALITÀ

Complimenti per aver scelto il letto *Invacare® Medley* prodotto da *Invacare®*.

Il vostro nuovo letto è marcato CE - ai sensi della Direttiva 93/42/EEC relativa ai dispositivi medici.

Il letto è stato progettato e costruito con un occhio di riguardo per gli utilizzatori e per i loro assistenti. *Invacare® Medley* è stato realizzato nel rispetto della Normativa Europea

EN 1970 /A1 & EN 60601.2.38.

Il letto è stato oggetto di accurate verifiche qualitative durante l'intero processo produttivo; una volta completato è stato controllato dal nostro servizio prodotti finiti.

Un'apposita targhetta e la marcatura QA sono state apposte sul letto a conferma dell'avvenuta verifica e accettazione del prodotto da parte del servizio qualità. Prima di utilizzare il letto vi invitiamo a leggere integralmente il manuale d'uso.

Invacare® è un'azienda certificata ai sensi della Normativa ISO 9001 e ISO 13485.

ES

DECLARACIÓN DE CALIDAD

Enhorabuena por su nueva cama *Invacare® Medley* de *Invacare®*.

Su nueva cama cuenta con el marcado CE - de acuerdo a la directiva 93/42/EEC que hace referencia a los aparatos médicos.

Invacare® Medley ha sido diseñada y fabricada teniendo en cuenta a los usuarios y las personas que los asisten.

La cama *Invacare® Medley* ha sido diseñada de acuerdo a la normativa Europea EN 1970 /A1 & EN 60601.2.38.

El proceso de producción del modelo *Invacare® Medley* ha sido supervisado en su totalidad y su calidad inspeccionada, por nuestro control de producto acabado.

La cama cuenta con una placa y marca CE que confirma que la misma ha sido inspeccionada por el control de producto acabado. Por favor lea el manual antes de utilizar la cama.

Invacare® es una empresa certificada ISO 9001 e ISO 13485

FR

DÉCLARATION DE QUALITÉ

Félicitations! Vous avez choisi votre nouveau lit *Invacare® Medley* de *Invacare®*.

Votre nouveau lit est marqué CE conformément à la directive 93/42/EEC concernant les dispositifs médicaux.

Invacare® Medley a été développé et construit en considérant systématiquement les besoins de l'utilisateur et des tierces personnes lors de la manipulation du lit ou de son utilisation.

Invacare® Medley a été développé conformément au Standard Européen NF EN 1970 /A1 & EN 60601.2.38.

Invacare® Medley a été supervisé et contrôlé tout au long du processus de fabrication et le lit achevé a été inspecté par le contrôle des produits finis. La plaque d'identification et la marque QA sont placées sur le lit attestant que le contrôle des produits finis a approuvé le lit. Le lit répond aux exigences de l'analyse de risques de la norme NF EN 14971. Nous vous remercions de lire le Manuel de l'Utilisateur dans son intégralité avant d'utiliser le lit.

Invacare® est certifiée ISO 9001 et ISO 13485.

PT

DECLARAÇÃO DE QUALIDADE

Parabéns pela sua nova cama *Invacare® Medley* da *Invacare®*.

A cama tem a marca CE - em conformidade com a directiva 93/42/EEC referente a aparelhos médicos.

A cama foi concebida e desenhada, tendo em consideração o seu utilizador e o seu(s) assistente(s), que o ajudarão a manipular a cama. A cama foi concebida em conformidade com o Standard Europeu EN 1970 /A1 & EN 60601.2.38.

Durante todo o processo de fabrico e produção, a cama *Invacare® Medley* foi inspeccionada e a sua qualidade controlada, sendo o produto final inspeccionado e testado pelo nosso controlo de qualidade. As etiquetas e a marca QA, são colocadas na cama, após a aprovação final da cama, confirmando e garantindo a conformidade com o nosso controlo de qualidade. Por Favor, leia atentamente este manual de utilizador antes de utilizar a sua cama.

A *Invacare®* está certificada em conformidade com ISO 9001 e ISO 13485.

PL

DEKLARACJA ZGODNOŚCI

Dziękujemy za obdarzenie nas zaufaniem i wybór naszego nowego produktu *Etude Medley* firmy *Invacare®*.

Łóżko pielęgnacyjne zostało zaklasyfikowane do grupy wyrobów medycznych i opatrzone znakiem CE zgodnie z dyrektywą 93/42/EWG.

Model *Etude Medley* zostały zaprojektowane przy uwzględnieniu indywidualnych potrzeb pacjentów i personelu medycznego oraz wyprodukowane zgodnie z wymaganiami europejskiej normy EN 1970/A1 & EN 60601.2.38.

Produkty firmy *Invacare®* są poddawane czystemu kontrolom z zakresu jakości podczas wszystkich etapów procesu produkcyjnego, a po zakończeniu procesu produkcyjnego kontroli końcowej.

Na produkcję została umieszczona tabliczka znamionowa oraz oznaczenie QA potwierdzające, że produkt został poddany wymaganym kontrolom jakości.

Przed rozpoczęciem użytkowania produktu należy zapoznać się z treścią niniejszej instrukcji obsługi.

Produkty firmy *Invacare®* posiadają certyfikat jakości zgodnie z normami ISO 9001 oraz ISO 13485.

Invacare® **Etude Medley**

USER MANUAL (GB)

GB

BEDIENUNGSANLEITUNG (DE)

DE

GEBRUIKSAANWIJZING (NL)

NL

MANUEL D'UTILISATION (FR)

FR

BRUGERVEJLEDNING (NO)

NO

MANUAL DEL USUARIO (ES)

ES

MANUALE D'USO (IT)

IT

MANUAL DE UTILIZAÇÃO (PT)

PT

Table of contents

1. General	6
2. Unpacking your product	9
3. Assembly of <i>Etude Medley</i>	10
4. Fitting the accessories	12
5. Operating the bed	15
5a. Operating beds with 3-sectioned mattress support	15
5b. Operating beds with 4-sectioned mattress support	16
5c. Adjustment of the leg section	17
5d. Operation of brakes	17
5e. Tilt function	17
6. Emergency lowering of the backrest and/or thigh section	18
7. Operating the accessories	19
8. Dismantling the <i>Etude</i> bed	20
9. Order numbers	21
10. Cleaning and disinfection	21
11. Maintenance and servicing	22
12. Maintenance chart	22
13. Disposal	23
14. Trouble-shooting the electrical system	24
15. Replacement of control unit and cables	25
16. Technical specifications	26
17. Weights	26
18. Electro Magnetic Compliance (EMC)	27

Congratulations

You have chosen an *Invacare*® **Etude Medley** nursing bed. **Etude Medley** are home nursing beds manufactured by *Invacare*® that are designed to be dismantled.

Invacare® is certified according to DS/EN ISO 9001 and ISO 13485 which ensures that our customers are always supplied with products of uniform quality.

Throughout the entire production process our materials/products are quality controlled by the operators. Additionally, a final test is carried out prior to packaging and shipping.

To identify the product please look at the Product-label.



If the product does not correspond to the quality demands of *Invacare*®, it will be discarded.



If, contrary to our expectations, a problem should arise in connection with the delivered product, please contact your *Invacare*® supplier. An address list is shown on the back side on this manual. *Invacare*® reserves the right to alter product specifications without prior notice.



Invacare® accepts no liability for any use, change or assembly of the product other than as stated in this user's manual.
Accessories not mentioned in this manual must not be used.

I. General

- The **Etude** nursing bed has been developed for domestic care and features a comfortable sitting and lying position for the patient. Furthermore, ergonomical operation for the carer is ensured. The bed is not intended for hospital use.
- The **Etude** bed is marked with the CE - mark in accordance with directive 93/42/EEC concerning Medical Apparatus.
- The **Etude** bed has been tested and approved according to EN 1970:2000 and EN 60601-2-38 + A1:2000. (EN 60601-2-38 + A1:2000 only according to the domestic care regulations).
- The motors and control of the **Etude** bed have been approved according to EN 60601:1996-03.
- The **Etude** bed has been approved and marked with the TÜV mark.
- The **Etude** bed has undergone a risk analysis according to EN ISO 14971:2001-03.
- The control unit, external power supply and motors are protected according to IP X4.
- The hand control unit is protected according to IP X4.
- Max. weight: 180 kg
- Max. patient weight: 145 kg (provided that the weight of the mattress and the accessories do not exceed 35 kg). **Important!** The max. load of the bed must not be exceeded.
- If the patient height exceeds 2 meters it is recommended to use a mattress support extension.
- The cabling consists of flexible cables with plugs at both ends, to ease replacement.
- The bed is not intended for children under 12 years and psychiatric patients.
- Remove the plug from the mains voltage before moving the bed. The cable must be kept clear off the floor and the castors during transportation.
- The adjustment area of the mattress support is: 40-80 cm or alternatively 33-73 cm. In standard or on low version 22-62 cm or alternatively 29-69 cm.
- The angle between the lower leg section and horizontal is adjustable from 0° to 15°.



It can be dangerous to roll over the mains cable.
Do not bring mains cable into moving parts.



Disconnect the plug from the mains before moving the bed.
The cables must be mounted in such a way that they are kept clear of the floor and do not block the castors.

We recommend to mount the mains cable on the hook for this purpose, see picture below.



Environment Conditions			
Temperature		Relative humidity	Atmospheric pressure
Storage			
From	- 10° C	20%	700 hPa
To	+ 50° C	75%	1060 hPa
Operating			
From	+ 5° C	20%	700 hPa
To	+ 40° C	75%	1060 hPa
Be aware that when a bed has been stored under low temperatures, it must adjusted to operating conditions before use.			



The bed's castors must be locked during nursing of a patient in bed or when using any positioning function.



Adjust the mattress support sections to horizontal position and lower the bed to its lowest position before moving the bed.
Hold the top of the bed end with both hands while the bed is pushed/pulled.
Any floor obstacle must not be higher than 10 mm.

If the functions of the bed change, check the bed according to the maintenance chart, chapter 12.



All service and maintenance work described in chapter 12 must only be performed by personnel who have been instructed and trained by *Invacare*®.



The **Etude** bed fulfils all requirements regarding maximum distances.
However, if the bed is used for the care of patients with a small body dimensions, it must be especially noted that there is a risk of such a patient slipping through the openings between the side rails or through the opening between the side rail and the mattress support.



The bed must not be used by patients under 12 years of age, or by patients with body size equivalent to an average 12-year-old or smaller.



Always lower the bed to the lowest position before leaving the patient in the bed unattended.



Electromagnetic interference between the bed and other electrical products can occur. To reduce or eliminate such electromagnetic interference, increase the distance between the bed and the products or switch them off.

This medical bed can be used together with medical electrical equipment connected to the heart (intracardially) or the blood vessels (intravascularly), provided that following points are respected:

- The medical bed should be equipped with means for potential equalization connection marked out by a symbol shown in the back of this manual.
- Medical electrical equipment should not be fixed on the bed's metallic accessories such as side rails, lifting pole, drip rod, bed ends ect.

In addition, the medical electrical equipment power supply cord should be kept clear of the accessories or any other moving part of the bed.



There is a risk of entrapment between the backrest and the cross rail on the head end of the mattress support. There is also a risk of getting squeezed between the leg section and the cross rail on the foot end of the mattress support when the backrest/leg section is lowered.



With the **Etude Medley** low version any floor obstacle has to be lower than 5 mm. Do not move the bed in the lower position, there is a risk of interference between a possible floor obstacle and the central unit.



Make sure that there are nothing under, over, or near the bed that can limit the movement of the bed or the mattress support, such as furniture, window frames and storage boxes.



Do not lift the bed by lifting the mattress support, there is a risk that the bed ends falls of the bed. Instead, lift the bed by the bed ends.

2. Unpacking your product

- Delivery:
1. Corrugated cardboard boxes
 2. Transport adaptor



For a complete bed the following parts must be provided:

Etude Medley

- A) 4-sectioned mattress support = ETUDE.ME300.M0
mattress support includes 2 mattress handles, hand control and motors mounted on the mattress support.



- B) Etude Medley : ETUDE.000M1.M1
Medley Low : MEDLEY.I535236.M1

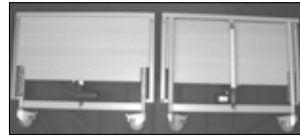

- C) Steel version with steel side rail:
1491226-0152

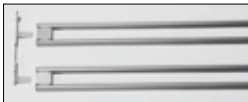

- Wood version with wooden side rail:
1491224-0101



- D) Lifting pole 50.57600.M0



Order numbers:

Mattress support:

ETUDE.ME300.M0

Etude Medley 4-sectioned mattress supports

Bed ends:

ETUDE.000M1.M1

Etude Medley (1 pair)

MEDLEY.I535236.M1

Medley Low (1 pair)

Side rails:

1491224-0101

Etude Medley wooden side rail (1 pair)

1491226-0152

Etude Medley steel side rail (1 pair)

Lifting pole:

50.57600.M0

Lifting pole

Standard silver is colour code **.M1** for the bed end and **.M0** for the mattress support.

3. Assembly of *Etude Medley*

(see illustration 1, 2a, 2b and 2c in front of the users manual)

a) Mattress support

- Place the two inserts in the head end of the mattress support. The inserts must be mounted in such a way that one extends further out of the side tube than the other.
- Loosely screw in the two finger screws.
- Push the foot end of the mattress support onto the two inserts.
- Tighten the two finger screws.
- Retighten the two finger screws at the head end of the top frame.
- Attach the two mattress support handles to the mattress support.



b) Bed end

- Turn the locking rings on the bed ends to the position "open".
- Latch the mattress support to the bed ends and press firmly into position.
- Turn the locking rings to the position "locked".

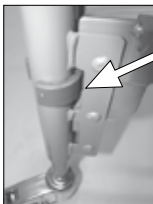

Position locked

c) Control unit

The control unit is latched to the backrest motor.

The control unit is provided with a label with symbols showing where to connect the plugs:

- Backrest motor.
- Thigh section's motor (on 4-sectioned beds).
- Bed end motors.
- Hand control.

Wiring

In order to prevent the cables from being torn apart when activating the motors, it is critical that you follow the instructions below:

- 1) Connect the cables of the bed end motors (head and foot end) directly to the control unit.
- 2) Wire the cable of the bed end motor (foot) and the leg motor through the pipe pins of the backrest motor.
- 3) Connect the mains cord to the 230V socket outlet (or the 24V cable and trafo on beds with external power supply).
- 4) Run the bed end motors to their top position.
- 5) Place the motor cable of the foot end on the hook at the foot end.
- 6) Run the backrest to its top position.
- 7) Place the bed end motor (head) cables on the hooks at the head end.
- 8) Fasten the locking cam to the control unit.

When working with the foot end, note that there is a risk of getting squeezed since the adjustable leg section is not firmly locked. Remember to remove the plug from the socket outlet when moving the bed.

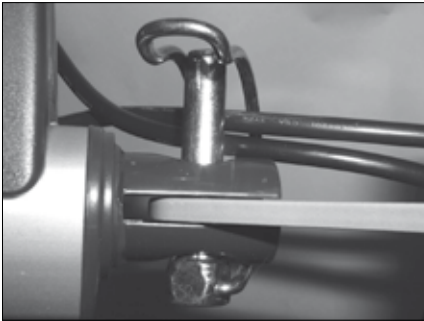

Wiring of the leg section motor and bed end motor (foot) through the backrest motor pipe pin.



Wiring of the bed end motor (foot).



Wiring at the lifting motor, head end.



(On Medley with separate power supply) connect the wire from the power supply to the wire from the control unit and secure the connection with the enclosed wire lock

4. Fitting the accessories

(see illustration 3 in front of the users manual)

Fitting the steel side rail

The side rail must be mounted with the release system at the head end of the bed.

The fork links on the side rail must be mounted according to the instruction on the side rail.

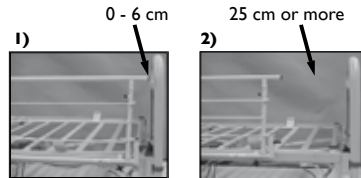
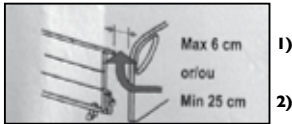

Tighten the side rail with 2 finger screws.

Fitting the side rails

The installation of steel- and wooden side rails are identical

- 1) The gliding system consists of 3 different parts which all must be installed simultaneously. A disassembled gliding system is shown in illustration A.

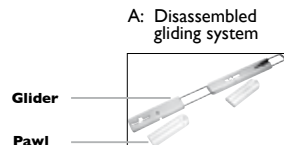

The two pawls are clipped onto the glider (B and C).

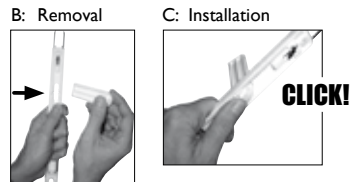

- 2) For an ergonomic working position and easier assembly, raise the bed to 1/3 of full height position. The gliding system of one bed end is guided into the bed end according to illustration D and E.

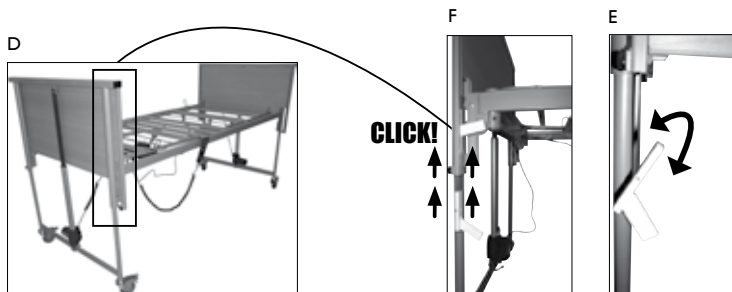

- 3) The upper side rail bar is installed according to illustration G.

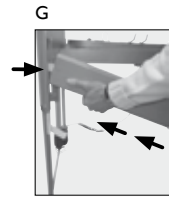

- 4) The gliding system in the opposite end are installed onto the upper side rail bar according to illustration H.



- 5) The side rail bar is raised until an audible click can be heard. Please be sure, that the gliding system has engaged properly into the first hole. (see illustration F and I).



- 6) The lower pawl is unfolded and the lower side rail bar is installed onto the pawl according to illustration E and J.

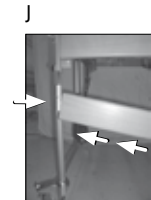

- 7) The lower pawl in the opposite end unfolded (see illustration E) and the lower side rail bar is then installed onto the lower pawl. Again, please ensure that pawls and gliders are completely engaged. (See illustration K).



- 8) The locking finger screws are installed and tightened.

- 9) On the Etude Medley low version, please set one warning sticker on each end of the lower pawls of the full length side rails. The 4 stickers are put in the bed ends packaging.





When lowering the side rails, there is a risk of entrapment between side rails and mattress support.



There is a risk of foot crushing between the floor and the lower pawl of the side rails when the mattress support and the side rails are in lower position.



There is a risk entrapment on assembly and operation of the side rails.

Fitting the lifting pole

Remove the plug from the lifting pole tube at the head end of the bed where the lifting pole is to be placed.
Insert the lifting pole into the lifting pole tube and secure it with the finger screw.



Fitting the wooden cover on *Medley* bed ends

- 1) Remove the two upper end plugs from both bed ends.
- 2) The wooden cover is placed onto the existing bed end, the two distance pieces placed inside the bed ends, and fastened with the four enclosed furniture screws.

Fitting the Rastofix bracket

Rastofix bracket can be fitted between leg section and top frame in the foot end, by using the supplied two pipe pins.

Battery for emergency lowering

An emergency lowering battery can be fitted onto 4-sectioned beds.

A LED lamp on the battery indicates that charging can take place.

Please be aware that the emergency lowering battery can only be attached to the leg motor on 4-sectioned beds.

Preventive battery maintenance

The accumulator has to be exchanged after 4 years. Depending on how the battery is used, the exchange may have to take place earlier. Frequent, sudden discharges reduces the battery's life.

We recommend that the accumulator is tested at least once a year. The accumulator is not damaged by continuous connection to the mains.

Exchanging the battery

The accumulator must be exchanged with an accumulator of the same type or a mechanically and electrically compatible accumulator (12V – 1,3Ah). The accumulators must be new or charged at least every 6 months for maintenance purposes.



Warning! Old or faulty accumulators may generate an explosive gas mixture during charging. The accumulator box is provided with vents to ensure adequate ventilation of the box. The vents must not be blocked or covered, as this may result in pressure build-up and the risk of explosion.

Waste disposal

Old accumulators may be returned to *Invacare*[®], alternatively they are disposed of like car batteries.



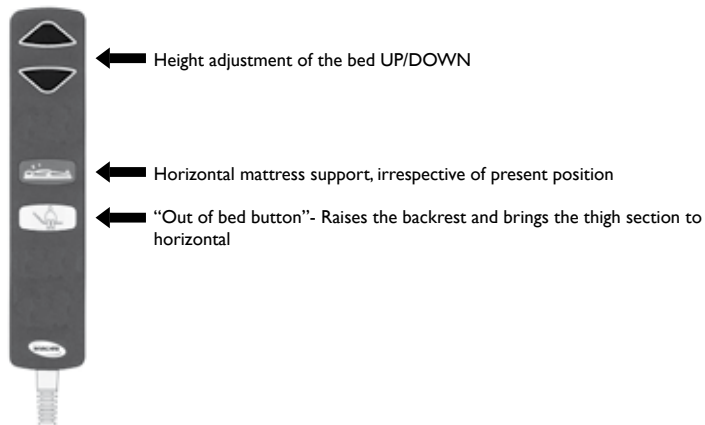

5. Operating the bed

5a. Operating beds with 3-sectioned mattress support

The bed can be equipped with this type of hand control (Soft Control):

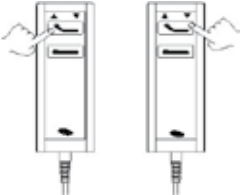

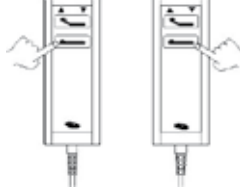
or with this type of hand control (HB 70):

<p>Backrest up</p>  <p>Button with the symbol shown above. Push the left-hand side of the button.</p>		<p>Backrest down</p>  <p>Button with the symbol shown above. Push the right-hand side of the button.</p>
<p>Height up</p>  <p>Button with the symbol shown above. Push the left-hand side of the button.</p>		<p>Height down</p>  <p>Button with the symbol shown above. Push the right-hand side of the button.</p>





5b. Operating beds with 4-sectioned mattress support

The bed can be equipped with this type of hand control (Soft Control):

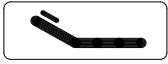
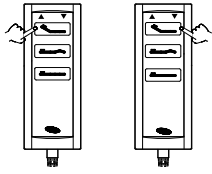

- ← Height adjustment of the bed UP/DOWN
- ← Sitting position, irrespective of present position
- ← Horizontal mattress support, irrespective of present position
- ← “Out of bed button”- Raises the backrest and brings the thigh section to horizontal
- ← Raises the thigh section and brings the backrest to horizontal

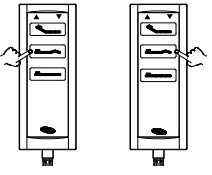
or with this type of hand control (HB 70):

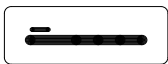
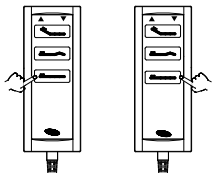
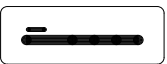
<p>Backrest up</p>  <p>Button with the symbol shown above. Push the left-hand side of the button.</p>		<p>Backrest down</p>  <p>Button with the symbol shown above. Push the right-hand side of the button.</p>
<p>Height up</p>  <p>Button with the symbol shown above. Push the left-hand side of the button.</p>		<p>Height down</p>  <p>Button with the symbol shown above. Push the right-hand side of the button.</p>
<p>Thigh section up</p>  <p>Button with the symbol shown above. Push the left-hand side of the button.</p>		<p>Thigh section down</p>  <p>Button with the symbol shown above. Push the right-hand side of the button.</p>



Adjustment of backrest - up/down
Use the button with the symbol shown on the left

Adjustment of the thigh section - up/down
Use the button with the symbol shown on the left

Height adjustment of mattress section - up/down
Use the button with the symbol shown on the left



Key for blocking and unblocking the electrical functions
Insert the key below each button to respectively block and unblock the hand control functions

5c. Adjustment of the leg section

(see illustration 4 in the back of the users manual)

The leg section can be adjusted **up/down** manually by using the handle located close to the bedend.

Up: Lift the leg section.

Down: Lift the leg section all the way up and then lower it.

5d. Operation of brakes

(see illustration 6 in the back of the users manual)

Each of the bed's 4 castors is provided with brakes for both lengthwise and crosswise locking. The brake is foot-operated.

When the bed is positioned correctly, at least one castor at the head end and one castor at the foot end must be locked.

1) Braking: Step on the pedal.

2) Releasing the brake: Step on the release pedal.

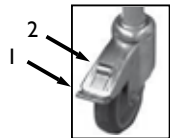

5e. Tilt function

Both 3 - and 4 - sectioned beds can be equipped with hand controls that activate the tilt of the mattress support.



The tilt function must only be operated by medically trained persons
- otherwise, there is a risk of injury to the patient's health.

Hand controls with tilt activating can be ordered from *Invacare*® - please refer to the section "Order numbers for accessories".



Always leave the bed in the lowest position. Otherwise there is a risk of entrapment due to accidental lowering of the mattress support. A person under the bed can be seriously injured during height adjustments. There is also a risk of entrapment between the leg section or backrest and bed frame when the backrest/leg section is lowered. Furthermore, there is a risk of entrapment between bed end and wheels when the mattress support is lowered.



There is a risk of entrapment between the backrest and the cross rail on the head end of the mattress support. There is also a risk of getting squeezed between the leg section and the cross rail on the foot end of the mattress support when the backrest/leg section is lowered.

6. Emergency lowering of the backrest and/or thigh section

(see illustration 5 in the back of the users manual)

An emergency release of the mattress support may be necessary in case of e.g. a power- or motor failure. An emergency release of the height adjustment is **NOT** possible.

Remove the plug from the mains before emergency release of the mattress support.



1) Hold the backrest.

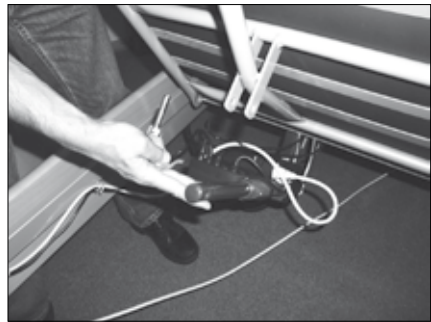

2) Remove the pipe pin from the backrest motor.

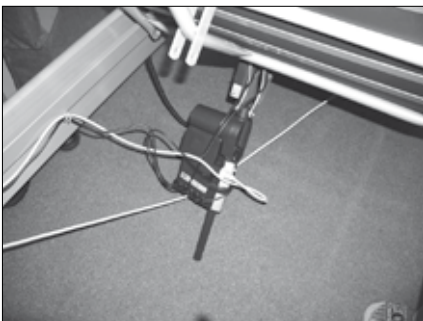

3) Lower the backrest motor.



4) Lower the backrest.



A **minimum of 2 persons** are required to emergency release a mattress section. Both persons hold the mattress section. One person pulls out the pipe pin. Both slowly lower the mattress section until it is completely down.

7. Operating the accessories

Operation of side rails - steel and wood

Up: Pull up the top side rail bar until the locking pin engages with an audible click.



Down: Lift the top side rail bar and press the latches inside the rail to disengage the locks. Lower the side rail.



There is a risk of entrapment when operating the side rails.

Adjusting the height of the lifting pole handle

Loosen the cord as shown in illustration A. The lifting handle can now be adjusted to the desired height. Press the cord together as shown in illustration B, and check that the cord is locked in the cord lock by pulling the handle.

Please notice that the string between the pole handle and lifting pole can be adjusted under consideration of the mattress height and the beds inclinations.

For a flexible use, we recommend, that both upper and lower bows in the handle are used.



A



B

The distance between the lifting pole and the mattress:

Etude

Mattress at 10 cm height: 55-78 cm

Mattress at 12 cm height: 53-76 cm



Always position the lifting pole in such a way that the handle extends inwards across the bed. If the lifting pole is used while the handle has been turned away from the bed, the bed can tip when used.

Fitting the mattress support extension

Disassemble the bed and remove the inserts. Mount the mattress support extension and the two mattress support parts, and reassemble the bed (see illustration 2a in the front of the users manual).

Choice of mattress

The standard mattress size for **Etude** bed is 90x200 cm. We recommend a mattress density of at least 35 kg/m³.

When the mattress support is positioned in the upper hinge position, a mattress of up to 12 cm (standard steel or wooden side rail).

When the mattress support is positioned in the lower hinge position, a mattress of up to 18 cm (standard steel or wooden side rail).

Metal side rails with extra height can be offered as an accessory, thus making mattress heights of up to 22 cm for **Etude Medley** possible.



Mattress heights (cm)		
Bed	Etude Medley	
Type of siderail	Wooden siderail	Metal siderail
Upper mattress support hinge position	10 - 12	10 - 12
Lower mattress support hinge position	10 - 18	10 - 18

8. Dismantling the Etude bed

- Remove side rails and lifting pole.
- Bring the bed to its lowest position and adjust all mattress support sections to horizontal position.
- Disconnect the mains cord (or the external power supply) from the socket outlet, and roll the cord onto the cable hook at the head end of the bed.
- Remove the locking cam from the control unit, by means of a flat bladed screwdriver.
- Pull out the cables for all motors.
- Remove the mattress support from the bed ends.
- Disassemble the mattress support.



9. Order numbers

50.57600.M0	Lifting pole
1491224-0101	Wooden side rail Etude Medley version (4 parts)
1510567-0101	Wooden cover for Etude Medley bed ends, beech
1491226-0152	Steel side rail Etude Medley version (4 parts)
1432784-0152	Steel side rail Scala Basic (1 pair)
1432781-0152	Steel side rail Scala Medium - suitable for mattress heights of 9 - 22 cm (1 pair)
1446380-0152	Extended mattress support +20 cm
1491305-0101	Extended wooden side rail Etude Medley version (4 parts) +20 cm
1417510-0152	Support handle 25x80 cm, 1 pcs.
1417511-0152	Support handle 40x30 cm, 1 pcs.
021963.M0	Support handle 40x50 cm, 1 pcs.
021964.M0	Support handle 25x30 cm, 1 pcs.
1417512-0152	Support handle 40x95 cm, 1 pcs.
1493223	Transport fittings, Medley, unpainted
1427838-7032	Transport fitting for Etude beds
1491299-7042	Mattress retainer
1423846	Hand control HB70 for 4 sectioned beds, with tilt function
1493521-7035	Hand control HL80 with integrated ACP function
1509466-7016	External power supply (transformer) with wire
1427714	Rastofix bracket for leg section

10. Cleaning and disinfection

Remove the mains plug from the socket outlet before cleaning.

The **Etude** bed does not tolerate cleaning in an automatic washing plant or using water-jet based cleaning equipment.

The bed should be washed down using a sponge, cloth or brush. Use ordinary disinfecting detergents.

When disinfecting only use spray or wiping methods. Only officially recognized disinfectants must be used.

Dry the bed after cleaning.

Never use acids, alkalines or solvents such as acetone or cellulose thinner.

The hand control, motors and control unit may be washed with brush and water; but not with pressurized water.



If the backrest is raised, be careful not to lower it unintentionally, as there is a risk of entrapment between the backrest and the top frame.

11. Maintenance and servicing

Service and maintenance of the bed must only be performed by personnel who have received the necessary instruction or training.

With normal daily use, service must be carried out according to the service schedule after 2 years use and thereafter every second year.

We recommend to use medical clean oil for lubrication (e.g. SCAN-WO, order no. 823239).

A service contract may be available in countries where *Invacare*® has own sales companies.

Furthermore, *Invacare*® offers courses in service and maintenance - please consult your local *Invacare*® company.

A spare part list can be obtained from *Invacare*®. Please note that electrical components can not be repaired.

We recommend to carry out cleaning and disinfection as well as maintenance and service prior to each re-issue of the bed into the community.

12. Maintenance chart

<p>Only personnel who have received the necessary instruction or training must perform service and maintenance of the Etude beds.</p> <p>S/N (located on mattress support): _____</p> <p>The bed should be serviced and tested by every relocation.</p>		
Date:	Initials:	Name (Print) and Signature
Visual inspection	In order	Unfunctional
The users manual and identification label is present.		
Visual inspection of all parts of the bed. (Plastic deformation and/or wear and tear of welded joints).		
All surfaces should be smooth and without burrs and sharp edges.		
Check the rivet in the bedends - rivets shall be completely fastened.		
Check the Rastofix fitting		
Visual inspection of all electrical equipment for damages.		
Check that mains cord, the plugs (and the external power supply) are undamaged.		
Check all remaining cables for damages. Also check the running of the cables.		
Mains cable as well as other electrical cables are placed in positions that prevents cutting, squeezing and other possible mechanical damages on the cables.		
Make sure that the transport hook in the head bed end, used to protect the cables during transportation, is undamaged.		
Check that there are no marks or scratches in the paint work on the frame and in the weldings - damaged paint must be repaired.		

Function inspection	In order	Unfunctional
All motors runs without defects, with normal speed and sound.		
Check the ACP blocking function.		
Check the motor's end stop.		
Test the side rails' fixations and locking/movement. The component should be undamaged and function without faults.		
Check the castors (braking and free rolling).		
The following parts must be lubricated: - Centers of rotation (motors and mattress support parts). - Centers of rotation of Rastofix fittings. (Lubricate with medically clean oil, e.g. KEW-WO 50). NB! The side rails' gliding system must not be lubricated with oil - otherwise the side rail bars will move sluggishly.		

13. Disposal

This product has been supplied from an environmentally aware manufacturer that complies with the Waste Electrical and Electronic Equipment (WEEE) Directive 2002/96/CE.

This product may contain substances that could be harmful to the environment if disposed of in places (landfills) that are not appropriate according to legislation.

The »crossed out wheellie bin« symbol is placed on this product to encourage you to recycle wherever possible.

Please be environmentally responsible and recycle this product through your recycling facility at its end of life.

All wooden parts must be dismantled and sent for incineration.

All electrical parts must be dismantled and disposed of as electrical waste.

Steel parts and castors must be disposed of as waste metals.

Plastic parts must be sent for incineration or recycling.

Waste disposal must comply with the laws and regulations pertaining waste handling in each country.

14. Trouble-shooting the electrical system

Service and maintenance of the **Etude** must only be performed by personnel who have received the necessary instruction or training. Please ensure that;

- 1) Mains power cord (or external power supply) is plugged in
- 2) Motor cables correctly fitted
- 3) There is no visual damage to the cables
- 4) Hand control is correctly mounted
- 5) ACP-box not in »Lock-position« (if fitted)

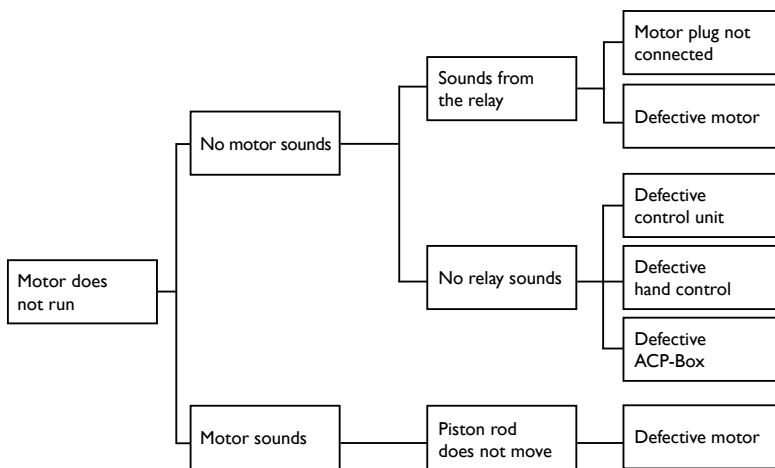

15. Replacement of control unit and cables



- 1) The control unit can be removed by taking away the retaining clips from the backrest motor.

Retaining clips



- 2) Pull the control unit sideways, away from the motor.



- 3) Remove the locking cam by unlatching the clips, and remove all motor and hand control plugs from the control unit. Installation is reverse of removal.

Installation of control unit



On **Etude Medley** all plugs should face downwards on the control unit.



16. Technical specifications

All measurements are stated in cm. All angles are stated in degrees. All measurements and angles are stated without tolerances.

Invacare® reserves the right to change the stated measurements and angles without previous warning. (see illustration 8 in the back of the users manual).

Voltage supply: 230V ~ ±10%, 50 Hz
 Max. current input: 1 A
 Voltage output: 24V ~ max. 70 VA
 Intermittent: 10%, max. 6 min/h (periodic motor operation)
 Protection class: IPX4
 Insulation class: II, type B
 Alternating current: 
 Direct current: 

The patient is not separated from the ground and the chassis



Double insulated



The bed is not provided with a mains switch, so the mains plug is the only separation from the mains.



= 180 kg Max. load (SWL) = (patient + mattress + siderail + lifting pole + other equipment)

The product should be reused where possible.



Lifting pole max. load (SWL): 80 kg

Sound level: 45-50 dB(A)

Potential equalization.



17. Weights

Etude Medley bed end, steel - 1 pcs.	16,0	kg
Mattress support, head end	20,0	kg
Mattress support, foot end	17,0	kg
Steel side rail - 1 rail	5,0	kg
Wooden side rail - 1 rail	4,0	kg
Lifting pole	7,0	kg
Mattress support extension (+20 cm)	5,5	kg
Etude Medley Select bed end wooden cover, 1 pcs.	6,5	kg

4-sectioned bed, complete excluding side rails and lifting pole,
 with **Etude Medley** bed end, steel 69,0 kg

4-sectioned bed, complete, including side rails and lifting pole,
 steel without **Select** covers. 86,0 kg

4-sectioned bed, complete, including side rails and lifting pole,
 wood, without **Select** covers. 84,0 kg

18. Electro Magnetic Compliance (EMC)

The Medical Bed is intended for use in the electromagnetic environment specified below. The user of the Medical bed should assure that it is used in such an environment.		
Emissions test	Compliance	Electromagnetic environment – guidance
RF emissions CISPR 11	Group I	The Medical Bed uses RF energy only for its internal function. Therefore, its RF emissions are very low and are not likely to cause any interference in nearby electronic equipment.
RF emissions CISPR 11	Class B	The Medical Bed is suitable for use in all establishments, including domestic establishments and those directly connected to the public low-voltage power supply network that supplies buildings used for domestic purposes.
Harmonic emissions IEC 61000-3-2	Class A	
Voltage fluctuations/ flicker emissions IEC 61000-3-3	Complies	

Guidance and manufacturer's declaration – electromagnetic immunity			
The Medical Bed is intended for use in the electromagnetic environment specified below. The user of the Medical should assure that it is used in such an environment.			
IMMUNITY test	IEC 60601 test level	Compliance level	Electromagnetic environment – guidance
Electrostatic discharge (ESD) IEC 61000-4-2	± 6 kV contact ± 8 kV air	± 6 kV contact ± 8 kV air	Floors should be wood, concrete or ceramic tile. If floors are covered with synthetic material, the relative humidity should be at least 30 %.
Electrical fast transient/burst IEC 61000-4-4	± 2 kV for power supply lines ± 1 kV for input/output lines	± 2 kV for power supply lines ± 1 kV for input/output lines	Mains power quality should be that of a typical commercial or hospital environment.
Surge IEC 61000-4-5	± 1 kV line(s) to line(s) ± 2 kV line(s) to earth	± 1 kV differential mode ± 2 kV common mode	Mains power quality should be that of a typical commercial or hospital environment.
Voltage dips, short interruptions and voltage variations on power supply input lines IEC 61000-4-11	<5 % UT (>95 % dip in UT) for 0,5 cycle 40 % UT (60 % dip in UT) for 5 cycles 70 % UT (30 % dip in UT) for 25 cycles <5 % UT (>95 % dip in UT) for 5 s	<5 % UT (>95 % dip in UT) for 0,5 cycle 40 % UT (60 % dip in UT) for 5 cycles 70 % UT (30 % dip in UT) for 25 cycles <5 % UT (>95 % dip in UT) for 5 s	Mains power quality should be that of a typical commercial or hospital environment. If the user of the Medical bed Alegio requires continued operation during power mains interruptions, it is recommended that the Medical Bed Alegio be powered from an uninterruptible power supply or a battery.
Power frequency (50/60 Hz) magnetic field IEC 61000-4-8	3 A/m	0,3 A/m	The power frequency magnetic field should be at a characteristic level of a typical commercial or hospital environment.
NOTE UT is the a.c. mains voltage prior to application of the test level.			

Guidance and manufacturer's declaration – electromagnetic immunity

The Medical bed is intended for use in the electromagnetic environment specified below. The user of the Medical Bed should assure that it is used in such an electromagnetic environment.

IMMUNITY test	IEC 60601 TEST LEVEL	Compliance level	Electromagnetic environment – guidance
Conducted RF IEC 61000-4-6	3 Vrms	1 Vrms	Portable and mobile RF communications equipment should be used no closer to any part of the Medical Bed, including cables, than the recommended separation distance calculated from the equation applicable to the frequency of the transmitter. Recommended separation distance $d = 3,5 \sqrt{P}$
	150 kHz to 80 MHz outside ISM bands ^a		
Radiated RF IEC 61000-4-3	10 Vrms	1 Vrms	$d = 12 \sqrt{P}$ $d = 1,2 \sqrt{P}$ 80 MHz to 800 MHz $d = 2,3 \sqrt{P}$ 800 MHz to 2,5 GHz where P is the maximum output power rating of the transmitter in watts (W) according to the transmitter manufacturer and d is the recommended separation distance in metres (m). ^b Field strengths from fixed RF transmitters, as determined by an electromagnetic site survey, ^c should be less than the compliance level in each frequency range. ^d Interference may occur in the vicinity of equipment marked with the following symbol: 
	150 kHz to 80 MHz in ISM bands ^a		
	10V/m	10V/m	
	80 MHz to 2,5 GHz		

NOTE 1 At 80 MHz and 800 MHz, the higher frequency range applies.

NOTE 2 These guidelines may not apply in all situations. Electromagnetic propagation is affected by absorption and reflection from structures, objects and people.

^a The ISM (industrial, scientific and medical) bands between 150 kHz and 80 MHz are 6,765 MHz to 6,795 MHz; 13,553 MHz to 13,567 MHz; 26,957 MHz to 27,283 MHz; and 40,66 MHz to 40,70 MHz.

^b The compliance levels in the ISM frequency bands between 150 kHz and 80 MHz and in the frequency range 80 MHz to 2,5 GHz are intended to decrease the likelihood that mobile/portable communications equipment could cause interference if it is inadvertently brought into patient areas. For this reason, an additional factor of 10/3 has been incorporated into the formulae used in calculating the recommended separation distance for transmitters in these frequency ranges.

^c Field strengths from fixed transmitters, such as base stations for radio (cellular/cordless) telephones and land mobile radios, amateur radio, AM and FM radio broadcast and TV broadcast cannot be predicted theoretically with accuracy. To assess the electromagnetic environment due to fixed RF transmitters, an electromagnetic site survey should be considered. If the measured field strength in the location in which the Medical Bed is used exceeds the applicable RF compliance level above, the Medical Bed should be observed to verify normal operation. If abnormal performance is observed, additional measures may be necessary, such as re-orienting or relocating the Medical Bed.

^d Over the frequency range 150 kHz to 80 MHz, field strengths should be less than 1 V/m.

**Recommended separation distances between
portable and mobile RF communications equipment and the Model 006**

The Medical Bed is intended for use in an electromagnetic environment in which radiated RF disturbances are controlled. The user of the Medical Bed can help prevent electromagnetic interference by maintaining a minimum distance between portable and mobile RF communications equipment (transmitters) and the Medical Bed as recommended below, according to the maximum output power of the communications equipment.

Rated maximum output power of transmitter W	Separation distance according to frequency of transmitter		
	150 kHz to 80 MHz $d = 1,2\sqrt{P}$	80 MHz to 800 MHz $d = 1,2\sqrt{P}$	800 MHz to 2,5 GHz $d = 2,3\sqrt{P}$
0,01	0,12	0,12	0,23
0,1	0,38	0,38	0,73
1	1,2	1,2	2,3
10	3,8	3,8	7,3
100	12	12	23

For transmitters rated at a maximum output power not listed above, the recommended separation distance d in metres (m) can be estimated using the equation applicable to the frequency of the transmitter, where P is the maximum output power rating of the transmitter in watts (W) according to the transmitter manufacturer.

NOTE 1 At 80 MHz and 800 MHz, the separation distance for the higher frequency range applies.

NOTE 2 These guidelines may not apply in all situations. Electromagnetic propagation is affected by absorption and reflection from structures, objects and people.



Customer Sales and Service

Denmark

INVACARE A/S

Sdr. Ringvej 37
DK-2605 Brøndby
Phone: +45 36 90 00 00
Fax: +45 36 90 00 01
www.invacare.dk
denmark@invacare.com

Sweden & Finland

INVACARE AB

Fagerstagatan 9 / Box 66
S-163 91 Spånga
Phone: +46 8 761 70 90
Fax: +46 8 761 81 08
www.invacare.se
sweden@invacare.com

Norway & Iceland

INVACARE AS

Grensesvingen 9
Postbox 6230 Etterstad
N-0603 Oslo
Phone: +47 22 57 95 00
Fax: +47 22 57 95 01
www.invacare.no
norway@invacare.com

Spain

INVACARE S.A.

C/Areny S/N
Poligon Industrial de Celrà
E-17460 Celrà (Girona)
Phone: +34 972 49 32 00
Fax: +34 972 49 32 20
www.invacare.es
contactsp@invacare.com

Switzerland

MOBITEC REHAB AG

Benkenstrasse 260
CH-4108 Witterswil
Phone: +41 61 487 70 80
Fax: +41 61 487 70 81
switzerland@invacare.com

Invacare®

Ident. no.: 1544338
Version: VB
Date: 09.2011

Belgium & Luxemburg

INVACARE N.V.

Autobaan 22
B-8210 Loppem, Brügge
Phone: +32 50 83 10 10
Fax: +32 50 83 10 11
www.invacare.be
belgium@invacare.com

Netherlands

INVACARE B.V.

Celsiusstraat 46
NL-6716 BZ Ede
Phone: +31 318 695 757
Fax: +31 318 695 758
www.invacare.com
nederland@invacare.com
csede@invacare.com

Germany

INVACARE@AQUATEC GmbH

Alemannenstrasse 10
D-88316 Isny
Phone: +49 75 62 7 00 0
Fax: +49 75 62 7 00 66
www.invacare-aquatec.de
info@invacare-aquatec.com

Portugal

INVACARE Lda

Rua Estrada Velha 949
P-4465-784 Leça do Balio
Phone: +351 225 1059 46/47
Fax: +351 225 1057 39
www.invacare.pt
portugal@invacare.com

Australia

INVACARE Australia Pty Ltd

1 Lenton Place, North Rocks
NSW 2151
Phone: +61 2 8839 5333
Fax: +61 2 8839 5353
www.invacare.com.au
sales@invacare.com.au

3rd party certified
according to
EN ISO 9001
EN ISO 13485

France

INVACARE Poirier S.A.S

Route de St. Roch
F-37230 Fondettes
Phone: +33 2 47 62 64 66
Fax: +33 2 47 42 12 24
www.invacare.fr
contactfr@invacare.com

Italy

INVACARE MECC SAN S.R.L.

Via dei Pini 62
I-36016 Thiene (VI)
Phone: +39 0445 38 00 59
Fax: +39 0445 38 00 34
www.invacare.it
italia@invacare.com

United Kingdom & Ireland

INVACARE LTD

Pencoed Technology Park,
Pencoed
UK-Bridgend CF35 5HZ
Phone: +44 1 656 776 200
Fax: +44 1 656 776 201
www.invacare.co.uk
uk@invacare.com
ireland@invacare.com

New Zealand

INVACARE NZ

4 Westfield Place,
Mt. Wellington
Auckland
Phone: +64 9 917 3939
Fax: +64 9 917 3957
www.invacare.co.nz
sales@invacare.co.nz

Austria

MOBITEC MOBILITÄTSHILFENGmbH

Herzog Odilostrasse 101
A-5310 Mondsee
Phone: +43 6232 5535 0
Fax: +43 6232 5535 4
www.mobitec-austria.com
austria@invacare.com

Manufacturer:

INVACARE Lda

Rua Estrada Velha 949
P-4465-784 Leça do Balio
www.invacare.pt